

# Enclosure Construction Manual for JBL Musical Instrument Loudspeakers

James B. Lansing Sound, Inc. 3249 Casitas Ave., Los Angeles, Calif. 90039

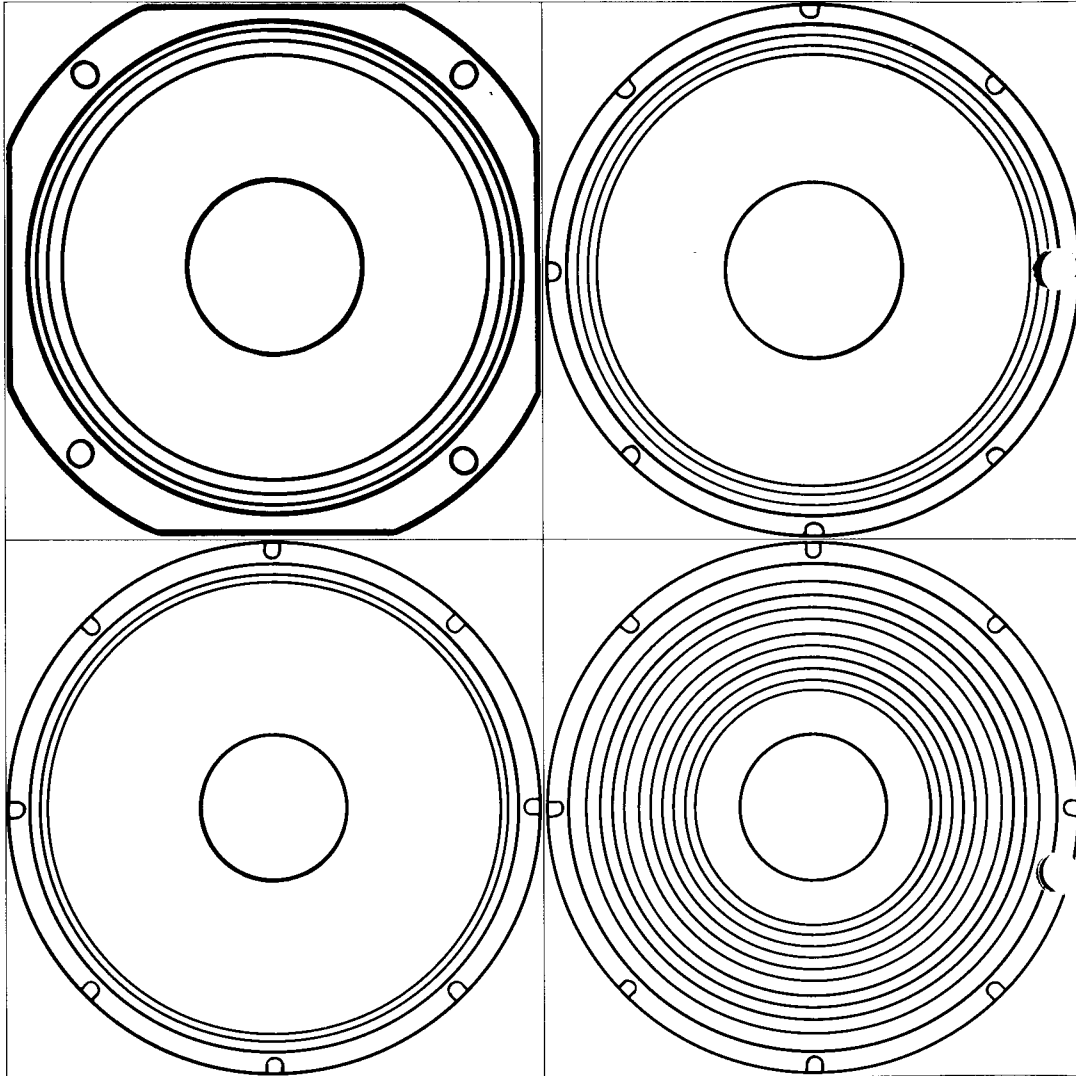

CF707 Printed in U.S.A.

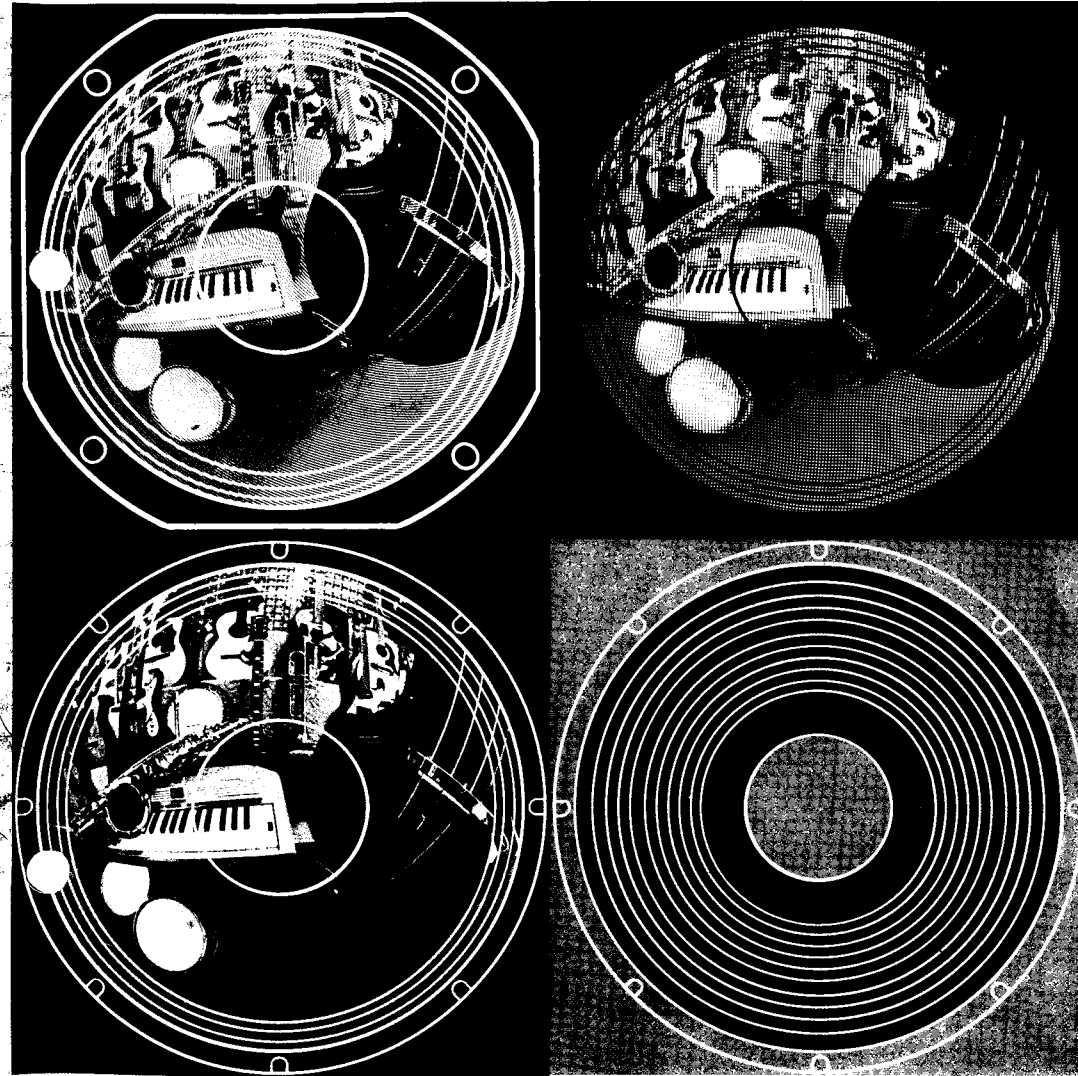

**JBL**

**JBL**

This publication has been prepared by JBL's Technical Service Department and is designed to help you get the best possible results from your JBL loudspeaker system. Enclosures designed to the following specifications will increase power-handling ability of JBL Musical Instrument Loudspeakers, reduce overload distortion and provide both greater dynamic range and better tone quality.

**FOR ADDITIONAL INFORMATION** JBL maintains a staff of technical experts who will be pleased to supply additional information about the installation and use of JBL Musical Instrument Loudspeakers. If you have any questions that are not answered in this publication, write directly to: Technical Service Department, James B. Lansing Sound, Inc., 3249 Casitas Avenue, Los Angeles, California 90039.

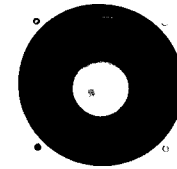

K-110  
D110F



K-120  
D120F

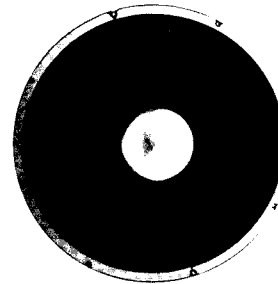
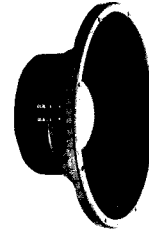

K-130  
D130F

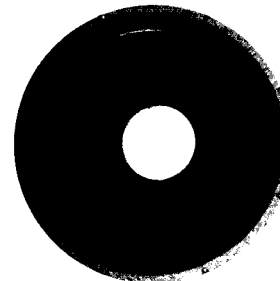
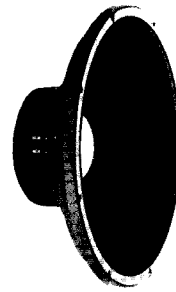

K-140  
D140F

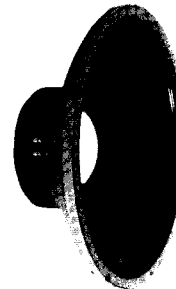

This publication has been prepared by JBL's Technical Service Department and is designed to help you get the best possible results from your JBL loudspeaker system. Enclosures designed to the following specifications will increase power-handling ability of JBL Musical Instrument Loudspeakers, reduce overload distortion and provide both greater dynamic range and better tone quality.

**FOR ADDITIONAL INFORMATION** JBL maintains a staff of technical experts who will be pleased to supply additional information about the installation and use of JBL Musical Instrument Loudspeakers. If you have any questions that are not answered in this publication, write directly to: Technical Service Department, James B. Lansing Sound, Inc., 3249 Casitas Avenue, Los Angeles, California 90039.

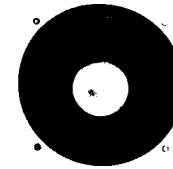

K-110  
D110F

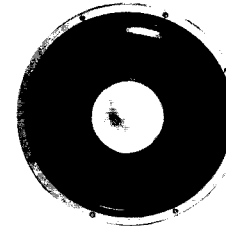

K-120  
D120F

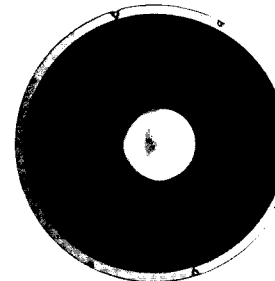

K-130  
D130F

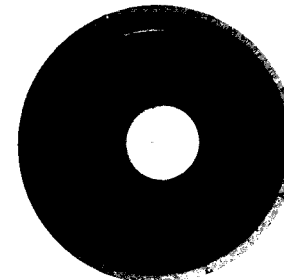

K-140  
D140F

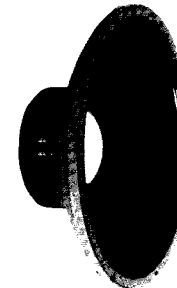

## Voice, Electric Guitar and Other Lead Instruments

The JBL D110F, D120F and D130F are recommended for use with voice, electric guitar, accordion, drums, saxophone, etc. Where space permits, the 15-inch D130F is preferable because of its larger cone area and greater sound output in the low frequency region. The D130F is also more efficient than a smaller speaker such as the D110F. For example, it takes two D110F's to deliver the same results as a single D130F.

The D110F and D120F are excellent choices for replacement of existing 10 and 12-inch speakers, and also for other applications where a lot of power is not needed, where portability is a prerequisite and for practice or recording sessions. The difference between these units is not overly important when considering lead instruments or voice, but remember that **two** loudspeakers will handle more power and put out more sound than a single speaker of the same size. The JBL D110F, D120F and D130F will deliver best performance in cabinets measuring 3.5 to 6.0 cubic feet (internal volume). For optimum results, the D130F should not be housed in cabinets smaller than 4.5 cubic feet.

## Bass Musical Instruments

For any bass musical instrument, we definitely recommend the JBL D140F. It delivers substantially greater sound output, heavier bass and greater power-handling capacity than any competitive speaker on the market. The D140F is the first high-quality loudspeaker designed specifically for bass instruments. When properly enclosed, the D140F will reproduce even the lowest organ pedal notes with greater efficiency than any other 15-inch speaker available. Its low frequency performance is crisp, clear and transparent... it contributes no coloration of its own to mask the waveform supplied by the musical instrument. A single D140F will give best performance in a very solidly built, ported cabinet having between four and six cubic feet of internal volume.

For professional applications, a six cubic foot ported cabinet housing two D140F's will deliver considerably more sound output with less chance of speaker overload than an enclosure containing a single D140F. Two six cubic foot ported cabinets, each housing two D140F's will not only give even more sound output, but also added flexibility so that the distribution of sound can be arranged to suit your own particular performance requirements.

If you want a system capable of delivering **thunderous** sound levels, you can combine loudspeakers in array. This is done by installing four D140F's in an eight to twelve cubic foot ported cabinet. One of these large cabinets set up on either side of the playing area will give the kind of coverage and power you need for large auditoriums, etc., where a great deal of background noise must be overcome. For a system of this size, we recommend a quality amplifier capable of delivering at least 50 watts of undistorted power per speaker, and we do not hesitate to recommend 75 watts per speaker. In other words, a 200 or 250 watt amplifier is not too much for a system this large.

There is no objection to using D120F's or D130F's for bass musical instruments so long as they are not overdriven. The D120F and D130F will deliver more sound for a given electrical signal than any comparable 12 or 15-inch loudspeaker. However, bass musical instruments exert greater demands on the loudspeaker than lead instruments... the speaker is required to handle more power through the frequency range where it has to work the hardest.

## Power-Handling Capacity

The amount of power a loudspeaker can absorb really doesn't tell you too much by itself. Loudspeakers vary in efficiency, and JBL units not only can handle tremendous power, but are extremely efficient as well. In other words, a JBL Musical Instrument Loudspeaker not only can take more punishment, but actually gives you more sound for a given amount of electrical power.

In tests conducted here at JBL, we have used a 250 watt amplifier and found it was possible to overload the amplifier before a D130F or D140F produced audible distortion on musical peaks. When properly enclosed, JBL Musical Instrument Loudspeakers can easily handle momentary peaks in excess of 100 watts.

We would like to emphasize however, that even a 30 watt amplifier can put out more than 150 watts peak if it is driven beyond its capabilities into the clipping region. When the amplifier is driven beyond its own limitations, it begins to "break up" internally and spurious signals are generated and fed to the speaker. Because the speaker is a passive instrument, it will only do what the amplifier "tells it to do," and a superior loudspeaker will do a much better job of reproducing a distorted signal just as it will do a much better job of reproducing a "clean" signal. This is why it is essential that the amplifier be well designed and constructed so that it will deliver reliable performance with a minimum of distortion. This means an amplifier that has plenty of reserve power... **clean** power that is still there when extremely high volume levels are required; enough power to drive the speaker to its full rated capacity.

JBL Musical Instrument Loudspeakers are more reliable, will handle more power and deliver more sound output than any other speakers available. However, keep in mind that any loudspeaker will be damaged if a great burst of electrical power (more power than it is capable of handling) is supplied to the voice coil terminals.

To get the great acoustical output demanded by a professional musician requires an exceptionally good speaker system, the greatest possible radiating area and a very powerful amplifier.

It also requires a substantial amount of proficiency on the part of the musician, since an amplifier that can play very loud without distortion can also supply enough power to blow out the speaker system if a reasonable amount of caution is not observed.

Whenever exceptionally high levels of acoustic output are required, it is a good idea to remember that more amplifier power and more loudspeakers generally are needed to get a worthwhile increase in loudness. If you have sufficient amplifier power available, you can get more sound power from two speakers than from a single speaker. Even if the two speaker system delivers twice as much sound power, it will not **sound** twice as loud. This is because of an inherent characteristic of the human ear and pertains to any sound system. For a system to sound twice as loud as another, it has to put out not twice as much, but **ten times** as much sound power. For example, two D130F's driven by a 100 watt amplifier will deliver twice the sound power of a single D130F driven by a 50 watt amplifier. The more powerful system will be noticeably louder, but not twice as loud.

## Sound Reinforcement

The choice of loudspeakers for a sound reinforcement or public address system depends upon the performance requirements of the musician and the environment in which he must perform. In some instances (such as small night clubs), a pair of D110F's, D120F's, or D130F's may be sufficient. On the other hand, one or two columns of D110F's or D120F's (four per column) will work fine in larger places where a great deal of sound output and wide dispersion are required. Occasionally, circumstances will dictate the utilization of massive driver-horn-lens assemblies along with appropriate low frequency loudspeakers, to provide the full, extended musical range and power needed for large auditoriums or outdoor settings where greater acoustical problems are usually encountered due to open air, large crowds and excessive background noise.

It is fairly common to run two or more electrical musical instruments through one amplifier and its speaker system. This can be done; however, it exerts a greater demand on the amplifier and the speaker system. For optimum performance and less chance of speaker and amplifier overload, we recommend a separate amplifier and speaker system for each electrical instrument. A sound reinforcement system used for voice should not be used with instruments, especially bass instruments.

The loudness of a sound reinforcement system depends upon the size of the room and its audience, acoustical properties of the room, distance from loudspeakers to audience and the amount of background noise level present. If a loudspeaker system is not delivering enough acoustic output, the solution is not to keep turning up the volume level of the amplifier into the region of greater and greater distortion, but to add more speakers and to increase the amount of amplifier power available (which means you may have to use more than one amplifier).

6

## Constructing the Enclosure

Successful selection of a sound reinforcement system depends upon many factors such as the acoustics and size of your playing areas, portability requirements, intensity of music needed, type of music, average size of listening audience, other instruments and components used, and whether or not it would be used for vocal reproduction, musical amplification or both.

These factors should be given careful consideration before constructing any cabinets or making a final choice on the kind and number of speakers to be used. For best results, the services of a professional acoustical consulting firm or sound contractor should be employed. If this is not possible, you may submit **detailed** information (including neat, informative drawings or blueprints) describing the factors mentioned previously, to JBL's Technical Service Department. JBL does not offer acoustical consulting service, but this information will assist us in evaluating your requirements and to offer possible recommendations. Keep in mind however, that there is no substitute for professional acoustical advice.

The cabinet must be well built and all joints should be true and tight. Lock-mitre joints glued under clamps are ideal if you have access to the necessary milling machinery. Some lumber yards and hobby shops will pre-cut the lumber to your requirements, mitre and prepare edges for joining. All joints should be reinforced with glue blocks running the entire length of the joint and screwed at 4-inch intervals to each surface to insure an airtight cabinet. An accumulation of small air leaks can introduce objectionable whistles and hisses and affect performance by decreasing substantially the amount of sound output in the low frequency region. All large panels should have 1" x 3" or 2" x 4" braces glued on edge about every 10 inches and fastened securely with screws to prevent any vibrations. Reproduction of bass notes particularly benefits from rigid enclosure construction.

7

Your enclosure should be constructed of ¾-inch material throughout, either plywood or particle board (pressed wood). Exact dimensions are not overly critical, but no dimension should be more than three times any other dimensions. For example, an enclosure measuring 1' x 2' x 4' is undesirable because of the 4-foot dimension (which is 4 times greater than the one-foot dimension).

About 50% of the surface area of the loudspeaker chamber should be lined with a soft, fluffy, absorptive material. The exact amount and placement of acoustic damping material can be varied over wide limits and adjusted by trial and error to give the degree of midrange brightness you prefer. The less padding used, the brighter and more "live" the midrange. The absorbent lining is usually arranged to cover half of the interior surface so that a padded wall faces an unpadded wall. The lining can be attached to the cabinet walls by using spots of glue, upholstery tacks or staples.

Ordinary one-inch acoustic glass wool works very well for this purpose, although any other soft, fluffy, absorptive material (such as Kimsul, Tufflex or felt rug padding) will do equally well. These can be purchased from any of the larger hi-fi dealers in your area or any firm specializing in insulation materials. We do **not** recommend that you use Celotex, foam rubber, styrofoam, rock wool, acoustic tile, cork, cotton, rubberized rug padding or kapok.

**Porting the Enclosure**

A ported enclosure is a speaker cabinet with a hole cut into the baffle panel (speaker mounting board). This hole has a carefully calculated area and is known as a port. In comparison to an infinite baffle (completely airtight cabinet), a ported enclosure extends bass response while improving fidelity. The port reinforces low notes, improves transient response and increases power-handling capacity while reducing distortion.

The correct port size is determined by two factors: the internal volume of the enclosure and the specific loudspeaker or loudspeakers installed in it. The internal volume of a loudspeaker enclosure can be calculated by multiplying the **internal** dimensions in inches (height x width x depth). Divide the resultant answer by 1728 (the number of cubic inches in a cubic foot). This figure will be the internal volume of your cabinet in cubic feet. When computing volume, area taken up by acoustical padding, bracing or the loudspeakers themselves should be disregarded. **Do not** subtract the area taken up by these items from the total internal volume figure.

The port can consist of any configuration (circular, square or rectangular) so long as the total open area equals our recommendation. For example, a 16 square inch port can be a circle having a diameter of 4.52 inches. (For circles, use the formula - Area = 3.14 x radius squared.) Divide the known area (16) by 3.14. The answer (5.12) = the radius squared. The square root of this will give you the radius (2.26). Multiply the radius by 2 and you will have the diameter (4.52). Thus, a circle with a 4.52 inch diameter will give you a port having the proper port area (16 square inches). For square or rectangular ports, simply multiply the height and width of the port opening and you will have the total open area in square inches. They can measure any combination of figures so long as you arrive at the recommended total open area. For example, a 16 square inch port can measure 4" x 4", 8" x 2", etc. Do not use a series of holes drilled in the baffle panel for a port.

You can have any number of ports in a cabinet, providing the total open area of the combined ports equals our recommendation. For example, if the port area is supposed to be 16 square inches, two separate cutouts measuring 4" x 2" is satisfactory.

Regardless of the number of speakers in the cabinet, the port area remains the same. For example, whether you have one or more D120F's installed in a 10 cubic foot cabinet, the port will still measure 98 square inches. The port size does not change regardless of the number of speakers used. The only factor which affects the size of the port is the internal volume of the cabinet and the kind of speaker to be used.

The port (or ports) can be positioned anywhere on the front baffle panel, so long as it isn't any closer than three inches to the speaker or the edges of the cabinet. The port should not be located on any surface other than the baffle panel.

If for some reason you are unable to cut a port having the same total open area recommended by JBL, a difference of ±10% in this area will not significantly affect the performance of your system.

There is one other point to remember in regard to porting: there is no scientific basis for the belief that a ported enclosure should be tuned to the free air resonance of the loudspeaker. Years ago, when all loudspeakers were made with light cones and resonances in the 40 to 60 cps. region, this was a conventional rule of thumb, but such is no longer the case. The minute a loudspeaker is installed in an enclosure, the system resonance changes and unless you know the efficiency, mass, compliance and radiating area of the loudspeaker, there is no way to compute the optimum port size.

**Port Sizes for Cabinets with the D110F, D120F & D130F (lead, rhythm, voice)**

Internal Volume of Cabinet In Cubic Feet	Port Size In Square Inches
3.0 - 3.5	16
3.6 - 4.0	20
4.1 - 4.5	28
4.6 - 5.0	36
5.1 - 5.5	40
5.6 - 6.0	45
6.1 - 6.5	54
6.6 - 7.0	58
7.1 - 7.5	65
7.6 - 8.0	72
8.1 - 8.5	78
8.6 - 9.0	84
9.1 - 9.5	90
9.6 - 10.0	98
10.1 - 10.5	106
10.6 - 11.0	112
11.1 - 11.5	118
11.6 - 12.0	124

**Port Sizes for Cabinets with the D140F (bass)**

Internal Volume of Cabinet In Cubic Feet	Port Size In Square Inches
3.0 - 3.5	10
3.6 - 4.0	18
4.1 - 4.5	21
4.6 - 5.0	24
5.1 - 5.5	26
5.6 - 6.0	28
6.1 - 6.5	30
6.6 - 7.0	32
7.1 - 7.5	35
7.6 - 8.0	38
8.1 - 8.5	40
8.6 - 9.0	42
9.1 - 9.5	45
9.6 - 10.0	50
10.1 - 10.5	54
10.6 - 11.0	60
11.1 - 11.5	65
11.6 - 12.0	70

**Bracing the Enclosure**

The following drawing illustrates the method of bracing recommended to bring out the full potential of your speaker system. Bracing can consist of any combination of vertical and horizontal reinforcement so long as all large panels are solidly braced. We recommend that bracing be made of 2" x 4" stock (usually soft pine), although 1" x 3" or 1" x 4" stock can be used if the enclosure must be made as light as possible.

You may not have to use as much bracing as illustrated in the drawing. It depends on the size of the cabinet and what kind of program material the speaker system will be reproducing. For instance, if bass musical instruments are used, the system will be constantly subjected to strong low frequency pulses that will increase the possibility of panel vibration (resonance). In this case, more bracing will prevent this from occurring. Any panel measuring 15" x 20" or more must be braced. A fairly large cutout or several cutouts on the baffle panel tend to weaken it and it will have to be braced regardless of its size. Also, the larger the cabinet, the more bracing needed. Be sure to position bracing so that it does not interfere with the proper placement of your speakers.

The most important thing is to make sure that the enclosure is solidly built and that all large panels have additional bracing attached, so that the enclosure will not vibrate even at high volume levels. The more rigid and non-resonant the enclosure, the firmer and clearer low frequency performance will be.

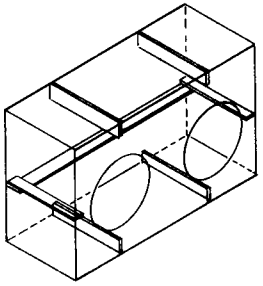

Typical Internal Bracing of Cabinet

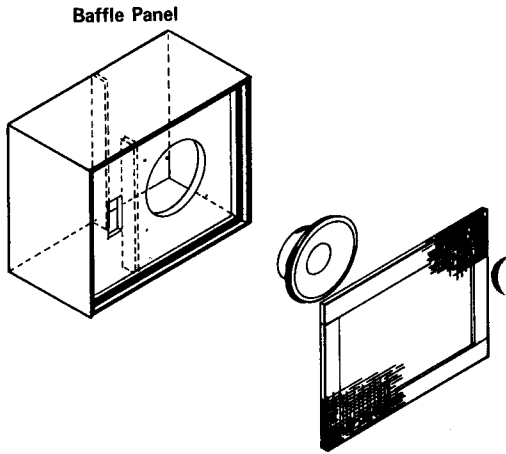

Typical Enclosure for a Single JBL D130F or Single D140F

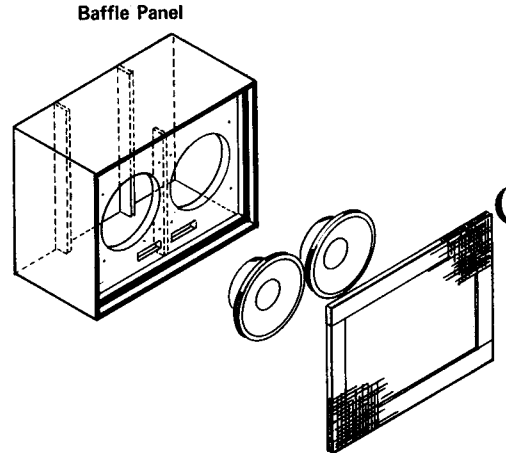

Typical Enclosure for Two JBL D140F's, D130F's, D120F's or D110F's

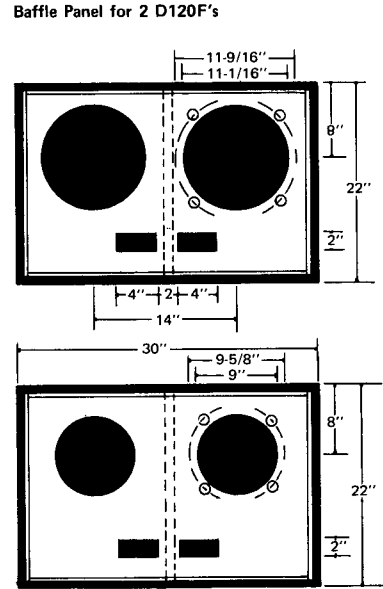

Baffle Panel for 2 D110F's

**Typical Enclosures with 3.5 Cubic Feet Internal Volume**

**Baffle Panel for Single D130F or Single D140F**

For single D130F, port measures 3" x 5 1/4"  
For single D140F, port measures 2" x 5"

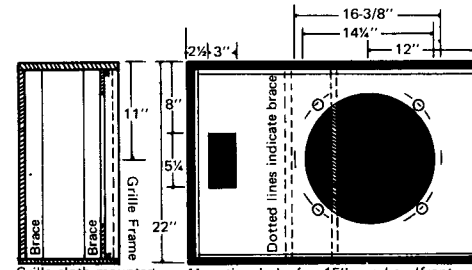
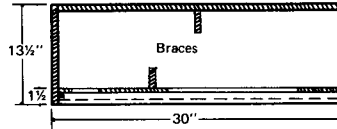

Grille cloth mounted on removable frame. Cloth spaced 3/8" from face of front panel. Mounting hole for 15" speaker (front mounting) is 1 1/4" diameter. Four bolt holes are spaced equally on 16-3/8" diameter circle. MA15 mounting kit is required.

**Typical Enclosures  
with 4.7 Cubic Feet Internal Volume**

(Larger Cabinet for Firmer  
and Smoother Bass in Bottom Range.)

**Baffle Panel for 2 D130F's or 2 D140F's**

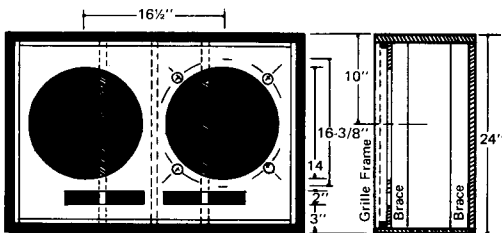
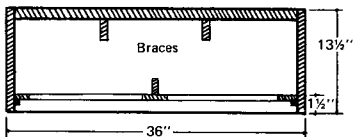

Port openings  
For D110F's, D120F's and D130F's,  
each port measures 2" x 9".  
For D140F's, each port measures 2" x 6".

Grille cloth mounted  
on removable frame.  
Cloth spaced 3/4" from  
face of front panel.

**Baffle Panel for 2 D120F's**

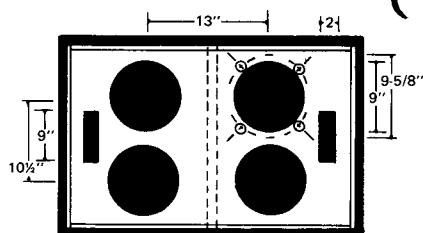
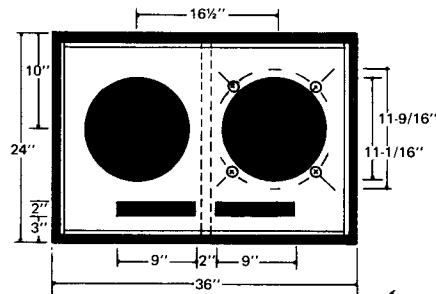

**Baffle Panel for 4 D110F's**

**Loudspeaker Wiring Connections**

**Installing the Speakers**

Connections to the amplifier should be followed according to the instructions in JBL publication OMFI, packed with every JBL Musical Instrument Loudspeaker.

Small holes can be drilled in the back of the enclosure to allow wiring from the speaker terminals to come out and be connected to the amplifier. Make sure that the wires fit snugly in the holes, otherwise air leakage will occur. A standard terminal strip can be used to make a neater, more professional installation. A phone plug or other connector is equally acceptable. Do not use connecting wires with standard AC plugs attached.

For maximum enclosure strength and rigidity, and for ease in installation, it is preferable to front-mount the loudspeakers. Front-mounting the JBL D130F or D140F requires the MA15 kit which consists of four small, cast clamps and necessary gasket material. This can be purchased through any franchised JBL dealer at \$3.90 per set. One set is required for each 15-inch speaker. If you intend to rear-mount the speaker, the back panel must be removable to allow insertion of the speaker. Wood screws spaced no more than six inches apart, will hold the back panel firmly in place.

Additional information on how to install and mount JBL Musical Instrument Loudspeakers are contained in the owner's manual (JBL publication OMFI).



## Testing the System

After the enclosure is built and the speaker is installed, test the system carefully, before you install the grille assembly, by playing all notes at the maximum loudness level which can be achieved without breakup. Operate the system at high volume and run your hand over the outside surface of the cabinet, noting any areas which vibrate appreciably. If any are found, they will have to be additionally braced. It may be necessary to go through this procedure more than once to achieve satisfactory rigidity. When this has been done, the enclosure will bring out the full low frequency capabilities of its loudspeaker system.

While testing the system, observe the motion of the speaker cone. **Make sure that the cone does not travel more than 1/4-inch or so.** (The only exception to this rule is the D140F, which can move up to 1/2-inch without being overdriven.) If the cone moves more than the recommended maximum, it indicates that too much power is being applied, that the cabinet may not be sufficiently braced or that the amplifier is unstable. Excessive bass boost at high volume also can result in using the full power of the amplifier at frequencies too low to be heard, and thereby overdriving the loudspeaker. If the speaker is used any length of time under conditions which results in excessive cone movement, it can be expected to break down short of its normal, useful life.

In some instances, you can increase the power-handling ability of the system by fastening a layer of glass wool to the rear of the front baffle panel tightly over the back of the speaker. This helps control the transient which is generated each time a string is plucked, but it also makes the overall sound less resonant.

After you are satisfied that you are getting optimum performance, the front of the speakers should be covered with a protective grille to prevent accidental damage. A metal grille consisting of a layer of expanded or perforated metal screen covered with standard speaker grille cloth will make a sturdy, good looking grille frame. The grille cloth should consist of a sturdy, loosely-woven fabric. It should have at least a 50% open area and it should be fairly porous and acoustically transparent to allow maximum dispersion and smooth performance.

It is a good idea to mount the metal screen and grille cloth on a separate thin, wooden frame so that the cloth is at least 1/8-inch away from the front of the baffle panel. This method of mounting keeps the loudspeakers and port from showing through the grille. The grille cloth should be stretched tightly over the grille frame, otherwise, the cloth will vibrate against the front panel on certain notes. Magnetic catches, spring dowels or friction clips can be used to secure the grille assembly to the cabinet. If you are building a simple utility enclosure, you can use oval-head screws and cup washers to mount the grille assembly.

JBL cannot make special recommendations about various brands of mixers, microphones, pickups, guitar amplifiers, etc. Our speakers have been used with a wide variety of these components and we can assure you that any of the top quality units are capable of very fine performance when used with JBL Musical Instrument Loudspeakers. The choice of specific models should be made with the help of your musical instrument dealer and knowledgeable musicians in your own field.

If you need literature or information about various brands of musical instruments, amplifiers, etc., we suggest that you write directly to the manufacturers. They are best qualified to provide information about their own products.

We cannot supply enclosures in kit form, nor can we supply pre-cut panels, hardware or custom-built cabinets. The enclosure designs shown in this publication have been engineered as a service to the home constructor. They are not available as factory-built items from JBL.

Items such as T-nuts, screws and cabinet hardware can be purchased from hardware or builder's supply stores in your area and are not available from JBL.

The JBL logo consists of the letters "JBL" in a bold, white, sans-serif font, centered within a solid black square.

James B. Lansing Sound, Inc.

3249 Casitas Ave., Los Angeles, Calif. 90039